

Condizioni di funzionamento / Working conditions

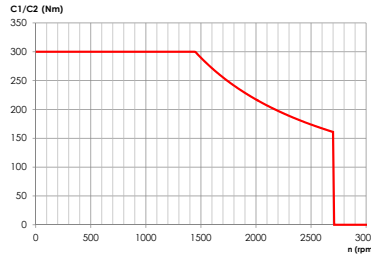

Coppie prelevabili per impiego singolo
 Max torque single use
 01203112138



Coppie prelevabili per impiego singolo
 Max torque single use
 01203012139

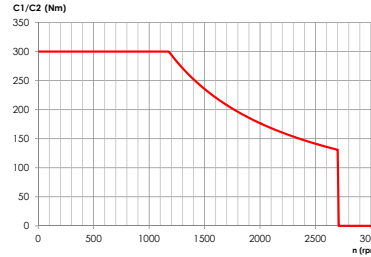

Coppie prelevabili per impiego simultaneo dei 2 utilizzi
 Max torque for using 2 outputs simultaneously

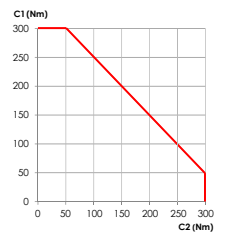

Il grafico qui riportato, che indica il prelievo di coppia in funzione del numero di giri, riguarda solamente la PTO. È necessario verificare il limite di prelievo di potenza dal cambio prima di effettuare l'applicazione.
 The graph indicating the allowed torque according to the RPM refers to the PTO only. It is necessary to check the torque limit of the gearbox before fitting the PTO.



Ingombro / Dimensions

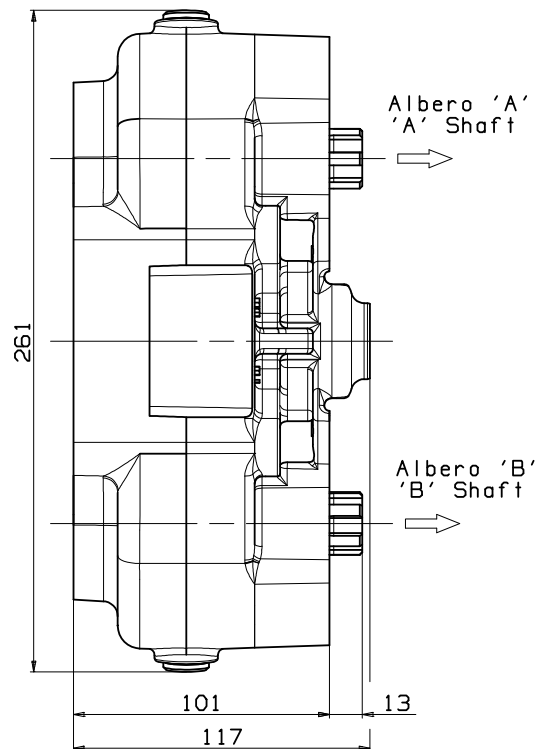
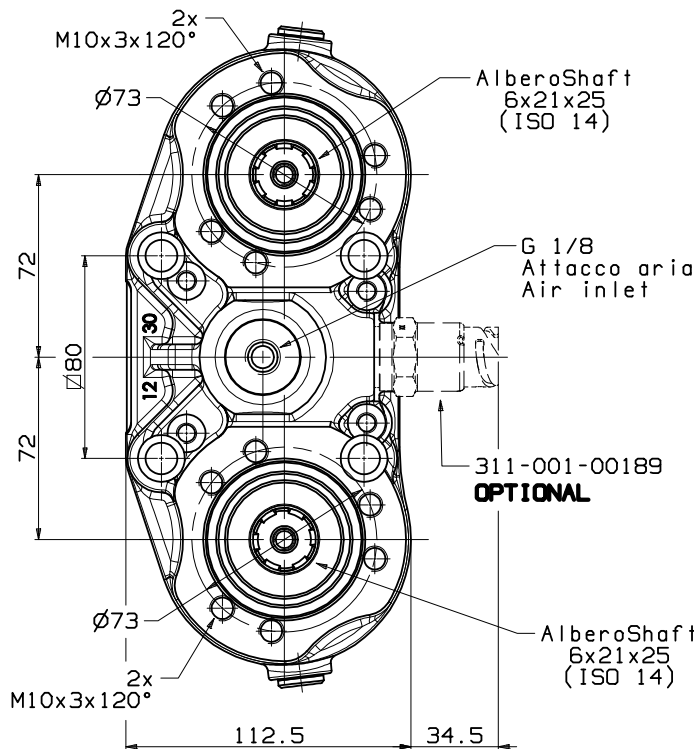

Dati tecnici / Technical data

Codice PTO PTO code	Rapporto interno Internal ratio	Versione Version	Giri PTO a 1000 giri motore Pto ratio@1000 eng.rpm	Coppia massima Max. torque	Rotazione Rotation	Peso Weight
			rpm	Nm		kg
01203012139	1:1.8	213	IN FUNZIONE DEI CAMBI ACCORDING TO THE GEARBOXES	300	Antioraria Ccw	11
01203112138	1:1.43					