

REINFORCED BELLOWS VACUUM CUPS WITH MALE AND FEMALE SUPPORTS

The particular shape of these bellows cups allows them to quickly crumple up when in contact with the surface of the load to be lifted and in presence of a vacuum. This quick movement prevents the load below from remaining stuck to the surfaces or load underneath.

Thanks to this particular feature, these bellows cups are recommended for handling paper and cardboard sheets, thin metal sheets, wooden panels, glass sheets etc.

Thanks to their great flexibility, they can also be used to compensate flatness errors or for gripping on inclined surfaces. Their anodised aluminium supports are provided with a threaded male or female central pin to allow suction and to fasten it to the automation. The vacuum cups can be fitted on them without the aid of adhesives.

To replace, simply request the single vacuum cup indicated in the table in the desired compound.



VACUUM CUPS

Item	Force Kg	Volume cm ³	A Ø	B Ø	C Ø	D Ø	E	F	H	Bellows stroke mm
01 22 19 *	0.95	2.5	14.5	5.0	11.0	22	4	5.5	19	10
01 34 26 *	2.26	8.0	14.5	5.0	17.0	34	4	5.5	26	12
01 43 28 *	3.62	15.3	20.0	6.5	21.5	43	4	7.0	28	14
01 53 35 *	5.51	30.5	27.0	10.5	30.5	53	6	9.5	35	16

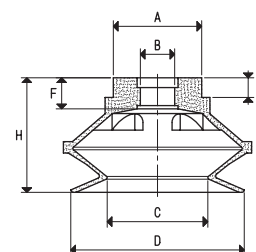

* Complete the code indicating the compound: A= oil-resistant rubber; N= natural para rubber; S= silicone

MALE SUPPORTS

Item	A Ø	B	C Ø	D Ø	E	F	G	H	Support material	For vacuum cup item	Weight g
00 08 133	14.5	13	G1/8"	8.5	5.5	8	5.0	18.5	aluminium	01 22 19 01 34 26	3.5
00 08 135	20.0	17	G1/4"	10.0	7.5	12	7.5	27.0	aluminium	01 43 28	9.5
00 08 142	27.0	22	G1/4"	14.0	7.5	12	9.5	29.0	aluminium	01 53 35	15.7

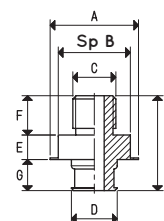

VACUUM CUPS WITH MALE SUPPORT

Item	Force Kg	A Ø	B	C Ø	D Ø	E	F	G	H	Vacuum cup item	Support item	Weight g
08 22 19 *	0.95	14.5	13	G1/8"	22	5.5	8	19	32.5	01 22 19	00 08 133	6.2
08 34 26 *	2.26	14.5	13	G1/8"	34	5.5	8	26	39.5	01 34 26	00 08 133	15.2
08 43 28 *	3.62	20.0	17	G1/4"	43	7.5	12	28	47.5	01 43 28	00 08 135	18.5
08 53 35 *	5.51	27.0	22	G1/4"	53	7.5	12	35	54.5	01 53 35	00 08 142	33.3

* Complete the code indicating the compound: A= oil-resistant rubber; N= natural para rubber; S= silicone

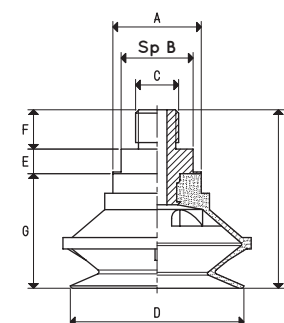

Note: The force of the vacuum cups indicated in the table represents 1/3 of the value of the theoretical force calculated at a level of vacuum of -75 KPa and a factor of safety 3.

Transformation ratio: N (newton) = Kg x 9.81 (force of gravity)

inch = $\frac{\text{mm}}{25.4}$; pounds = $\frac{\text{g}}{453.6} = \frac{\text{Kg}}{0.4536}$

Adapters for GAS - NPT threading available on page 1.130



REINFORCED BELLOWS VACUUM CUPS WITH FEMALE SUPPORTS

3D drawings are available on vuotecnica.net

1



VACUUM CUPS

Item	Force Kg	Volume cm ³	A Ø	B Ø	C Ø	D Ø	E	F	H	Bellows stroke mm
01 22 19 *	0.95	2.5	14.5	5.0	11.0	22	4	5.5	19	10
01 34 26 *	2.26	8.0	14.5	5.0	17.0	34	4	5.5	26	12
01 43 28 *	3.62	15.3	20.0	6.5	21.5	43	4	7.0	28	14
01 53 35 *	5.51	30.5	27.0	10.5	30.5	53	6	9.5	35	16

* Complete the code indicating the compound: A= oil-resistant rubber; N= natural para rubber; S= silicone

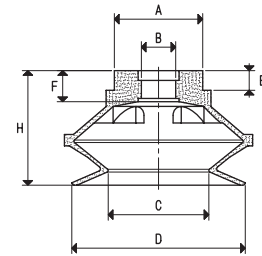

FEMALE SUPPORTS

Item	A Ø	B	C Ø	D Ø	E	F	G	H	Support material	For vacuum cup item	Weight g
00 08 132	14.5	13	G1/8"	8.5	8	12	5.0	17.0	aluminium	01 22 19 01 34 26	3.8
00 08 134	20.0	17	G1/4"	10.0	10	14	7.5	21.5	aluminium	01 43 28	8.3
00 08 141	27.0	22	G1/4"	14.0	10	14	9.5	23.5	aluminium	01 53 35	19.7

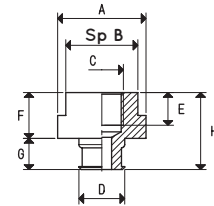

VACUUM CUPS WITH FEMALE SUPPORT

Item	Force Kg	A Ø	B	C Ø	D Ø	E	F	G	H	Vacuum cup item	Support item	Weight g
08 22 19 F *	0.95	14.5	13	G1/8"	22	8	12	19	31	01 22 19	00 08 132	6.5
08 34 26 F *	2.26	14.5	13	G1/8"	34	8	12	26	38	01 34 26	00 08 132	9.5
08 43 28 F *	3.62	20.0	17	G1/4"	43	10	14	28	42	01 43 28	00 08 134	17.3
08 53 35 F *	5.51	27.0	22	G1/4"	53	10	14	35	49	01 53 35	00 08 141	37.3

* Complete the code indicating the compound: A= oil-resistant rubber; N= natural para rubber; S= silicone

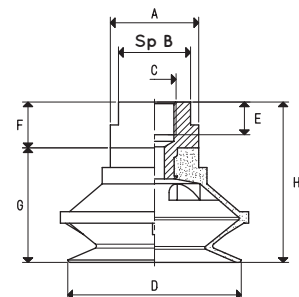

Note: The force of the vacuum cups indicated in the table represents 1/3 of the value of the theoretical force calculated at a level of vacuum of -75 KPa and a factor of safety 3.

Transformation ratio: N (newton) = Kg x 9.81 (force of gravity)

inch = $\frac{\text{mm}}{25.4}$; pounds = $\frac{\text{g}}{453.6} = \frac{\text{Kg}}{0.4536}$

Adapters for GAS - NPT threading available on page 1.130

REINFORCED BELLOWS VACUUM CUPS WITH SUPPORTS

The cups described on these pages share the same features with the previously described bellows cups, only these have larger dimensions that allow them to lift much heavier loads; moreover, their anodised aluminium supports also have a central threaded hole for their fastening to the automation. The larger ones also have an additional side hole for vacuum connection. The difference is that these supports are provided with a disc instead of with a pin. These cups can be cold fitted onto their supports without any adhesives. To replace, simply request the single vacuum cup indicated in the table in the desired compound.



VACUUM CUP

Item	Force Kg	Volume cm ³	A Ø	B Ø	C Ø	D Ø	G	H	M Ø	Bellows stroke mm
01 75 42 *	11.93	89.4	59	54	45	78	22.5	42	56	22.5

* Complete the code indicating the compound: A= oil-resistant rubber; N= natural para rubber; S= silicone

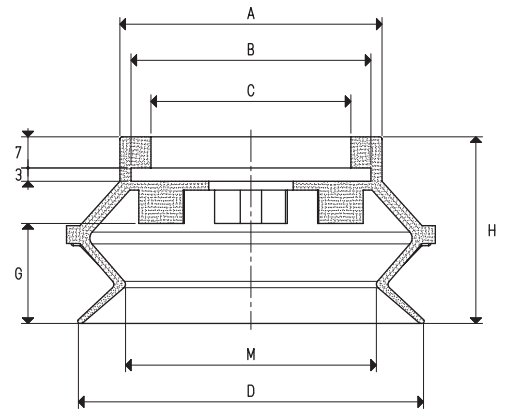

SUPPORTS

Item	A Ø	B Ø	D Ø	E	H	Support material	For vacuum cup item	Weight g
00 08 126	45	M12	54	3	10	aluminium	01 75 42	45.5
00 08 465	45	G1/4"	54	3	10	aluminium	01 75 42	41.5
00 08 193	45	G3/8"	54	3	10	aluminium	01 75 42	41.5
00 08 143	45	G1/2"	54	3	10	aluminium	01 75 42	41.5

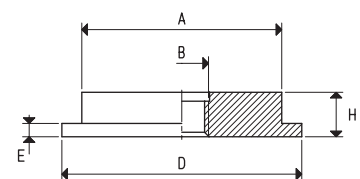

VACUUM CUPS WITH SUPPORT

Item	Force Kg	A Ø	B Ø	D Ø	G	H	Vacuum cup item	Support item	Weight g
08 75 42 *	11.93	59	M12	78	22.5	42	01 75 42	00 08 126	94.8
08 75 42 1/4" *	11.93	59	G1/4"	78	22.5	42	01 75 42	00 08 465	90.8
08 75 42 3/8" *	11.93	59	G3/8"	78	22.5	42	01 75 42	00 08 193	90.8
08 75 42 1/2" *	11.93	59	G1/2"	78	22.5	42	01 75 42	00 08 143	90.8

* Complete the code indicating the compound: A= oil-resistant rubber; N= natural para rubber; S= silicone

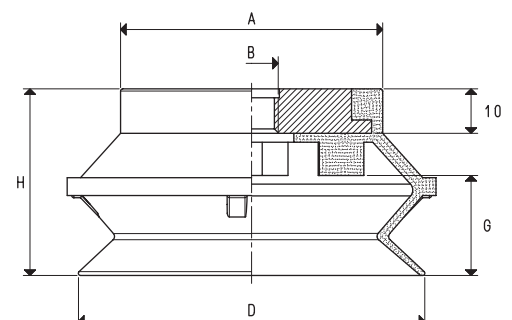

Note: The force of the vacuum cups indicated in the table represents 1/3 of the value of the theoretical force calculated at a level of vacuum of -75 KPa and a factor of safety 3.

Transformation ratio: N (newton) = Kg x 9.81 (force of gravity)

inch = $\frac{\text{mm}}{25.4}$; pounds = $\frac{\text{g}}{453.6} = \frac{\text{Kg}}{0.4536}$

Adapters for GAS - NPT threading available on page 1.130



REINFORCED BELLOWS VACUUM CUPS WITH SUPPORTS

3D drawings are available on vuotecnica.net



VACUUM CUPS

Item	Force Kg	Volume cm ³	A Ø	B Ø	C Ø	D Ø	G	H	M Ø	Bellows stroke mm
01 110 58 *	23.70	281.9	75	70	61	110	33	58	74	33
01 150 74 *	45.00	726.1	112	107	98	150	49	74	103	49

* Complete the code indicating the compound: A= oil-resistant rubber; N= natural para rubber; S= silicone

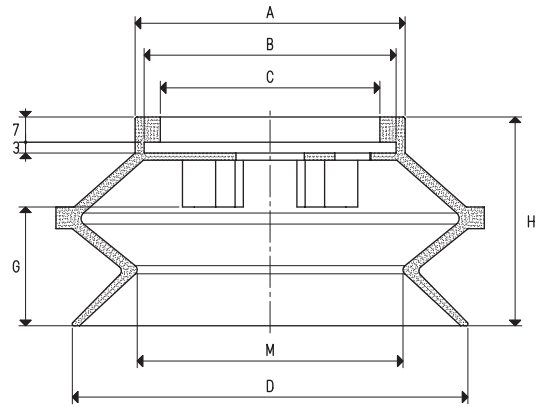

SUPPORTS

Item	A Ø	B Ø	C Ø	D Ø	E	N	H	Support material	For vacuum cup item	Weight g
00 08 162	61	G1/2"	G1/8"	70	3	23	10	aluminium	01 110 58	78.9
00 08 163	98	G1/2"	G1/8"	107	3	35	10	aluminium	01 150 74	211.8

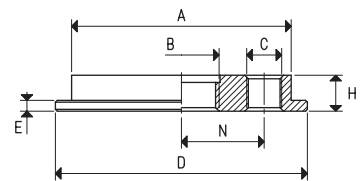

VACUUM CUPS WITH SUPPORT

Item	Force Kg	A Ø	B Ø	C Ø	D Ø	H	N	Vacuum cup item	Support item	Weight g
08 110 58 *	23.70	75	G1/2"	G1/8"	110	58	23	01 110 58	00 08 162	190.7
08 150 74 *	45.00	112	G1/2"	G1/8"	150	74	35	01 150 74	00 08 163	458.7

* Complete the code indicating the compound: A= oil-resistant rubber; N= natural para rubber; S= silicone

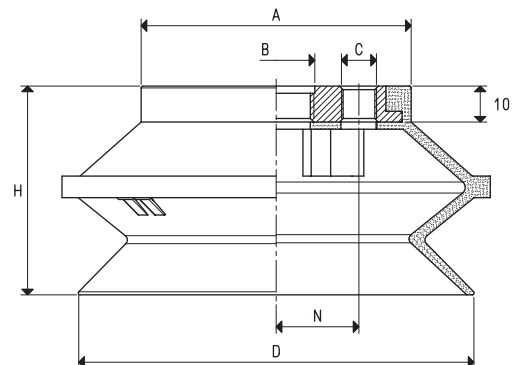

Note: The force of the vacuum cups indicated in the table represents 1/3 of the value of the theoretical force calculated at a level of vacuum of -75 KPa and a factor of safety 3.

Transformation ratio: N (newton) = Kg x 9.81 (force of gravity)

inch = $\frac{\text{mm}}{25.4}$; pounds = $\frac{\text{g}}{453.6} = \frac{\text{Kg}}{0.4536}$

Adapters for GAS - NPT threading available on page 1.130

REINFORCED BELLOWS VACUUM CUPS WITH SUPPORTS

The cups described on these pages share the same features with the previously described bellows cups, only these have larger dimensions that allow them to lift much heavier loads; moreover, their anodised aluminium supports also have a central threaded hole for their fastening to the automation. The larger ones also have an additional side hole for vacuum connection. The difference is that these supports are provided with a disc instead of with a pin. These cups can be cold fitted onto their supports without any adhesives. To replace, simply request the single vacuum cup indicated in the table in the desired compound.



VACUUM CUP

Item	Force Kg	Volume cm ³	A Ø	B Ø	C Ø	D Ø	G	H	M Ø	Bellows stroke mm
01 75 42 *	11.93	89.4	59	54	45	78	22.5	42	56	22.5

* Complete the code indicating the compound: A= oil-resistant rubber; N= natural para rubber; S= silicon

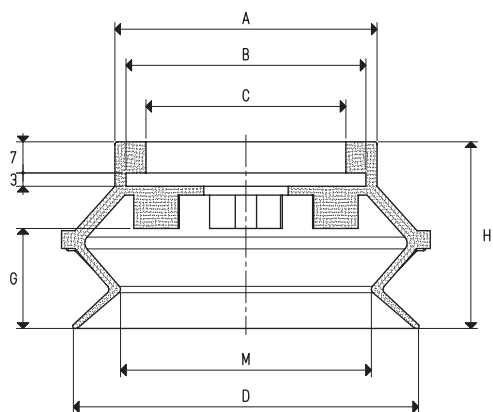

SUPPORTS

Item	A Ø	B Ø	D Ø	E	H	Support material	For vacuum cup item	Weight g
00 08 126	45	M12	54	3	10	aluminium	01 75 42	45.5
00 08 465	45	G1/4"	54	3	10	aluminium	01 75 42	41.5
00 08 193	45	G3/8"	54	3	10	aluminium	01 75 42	41.5
00 08 143	45	G1/2"	54	3	10	aluminium	01 75 42	41.5

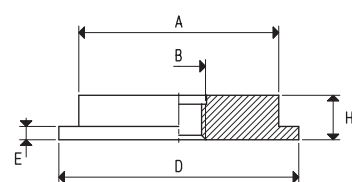

VACUUM CUPS WITH SUPPORT

Item	Force Kg	A Ø	B Ø	D Ø	G	H	Vacuum cup item	Support item	Weight g
08 75 42 *	11.93	59	M12	78	22.5	42	01 75 42	00 08 126	94.8
08 75 42 1/4" *	11.93	59	G1/4"	78	22.5	42	01 75 42	00 08 465	90.8
08 75 42 3/8" *	11.93	59	G3/8"	78	22.5	42	01 75 42	00 08 193	90.8
08 75 42 1/2" *	11.93	59	G1/2"	78	22.5	42	01 75 42	00 08 143	90.8

* Complete the code indicating the compound: A= oil-resistant rubber; N= natural para rubber; S= silicon

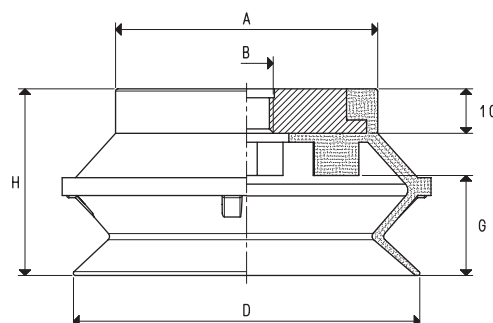

Note: The force of the vacuum cups indicated in the table represents 1/3 of the value of the theoretical force calculated at a level of vacuum of -75 KPa and a factor of safety 3.

Transformation ratio: N (newton) = Kg x 9.81 (force of gravity)

$$\text{inch} = \frac{\text{mm}}{25.4}; \text{pounds} = \frac{\text{g}}{453.6} = \frac{\text{Kg}}{0.4536}$$

Adapters for GAS - NPT threading available on page 1.130



REINFORCED BELLOWS VACUUM CUPS WITH SUPPORTS

3D drawings are available on vuototecnica.net

1



VACUUM CUPS

Item	Force Kg	Volume cm ³	A Ø	B Ø	C Ø	D Ø	G	H	M Ø	Bellows stroke mm
01 110 58 *	23.70	281.9	75	70	61	110	33	58	74	33
01 150 74 *	45.00	726.1	112	107	98	150	49	74	103	49

* Complete the code indicating the compound: A= oil-resistant rubber; N= natural para rubber; S= silicon

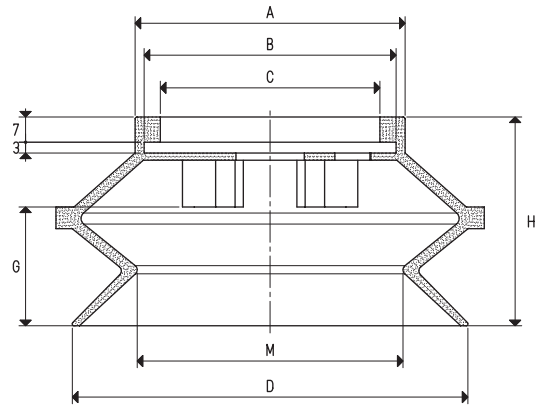

SUPPORTS

Item	A Ø	B Ø	C Ø	D Ø	E	N	H	Support material	For vacuum cup item	Weight g
00 08 162	61	G1/2"	G1/8"	70	3	23	10	aluminium	01 110 58	78.9
00 08 163	98	G1/2"	G1/8"	107	3	35	10	aluminium	01 150 74	211.8

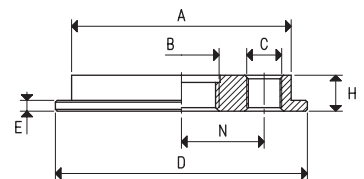

VACUUM CUPS WITH SUPPORT

Item	Force Kg	A Ø	B Ø	C Ø	D Ø	H	N	Vacuum cup item	Support item	Weight g
08 110 58 *	23.70	75	G1/2"	G1/8"	110	58	23	01 110 58	00 08 162	190.7
08 150 74 *	45.00	112	G1/2"	G1/8"	150	74	35	01 150 74	00 08 163	458.7

* Complete the code indicating the compound: A= oil-resistant rubber; N= natural para rubber; S= silicon

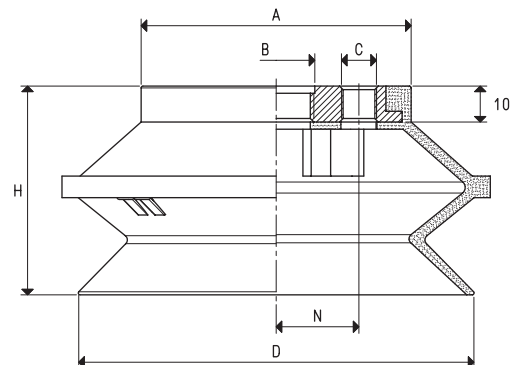

Note: The force of the vacuum cups indicated in the table represents 1/3 of the value of the theoretical force calculated at a level of vacuum of -75 KPa and a factor of safety 3.

Transformation ratio: N (newton) = Kg x 9.81 (force of gravity)

inch = $\frac{\text{mm}}{25.4}$; pounds = $\frac{\text{g}}{453.6} = \frac{\text{Kg}}{0.4536}$

Adapters for GAS - NPT threading available on page 1.130